



Dialight

**Vigilant[®] LED High Bay 480V AC Passive
Power Supply - UL / CSA**

for Indoor and Outdoor Industrial Applications

On when it matters most.

Products and solutions that protect your business

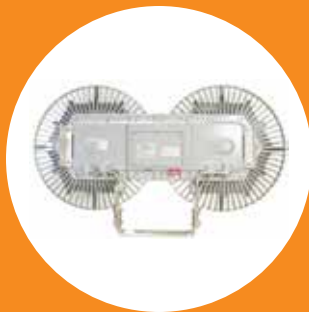



Features & Benefits

- 10 year full performance warranty
- L70 rated for >150,000 hours
- Instant on/off
- Mercury free
- No UV or IR
- Resistant to shock and vibration

Application

Dialight's 480V AC Vigilant® LED High Bay fixture was designed specifically to replace conventional lighting in a wide variety of industrial applications; both indoor and outdoor. Its low profile light weight design and versatile mounting options make it ideal for many applications such as warehouse, garage, aisle, cold storage, bridge, tunnel and general area lighting.

Vigilant® LED High Bay 480V AC Passive Power Supply - UL / CSA

Standard Models



Patent pending

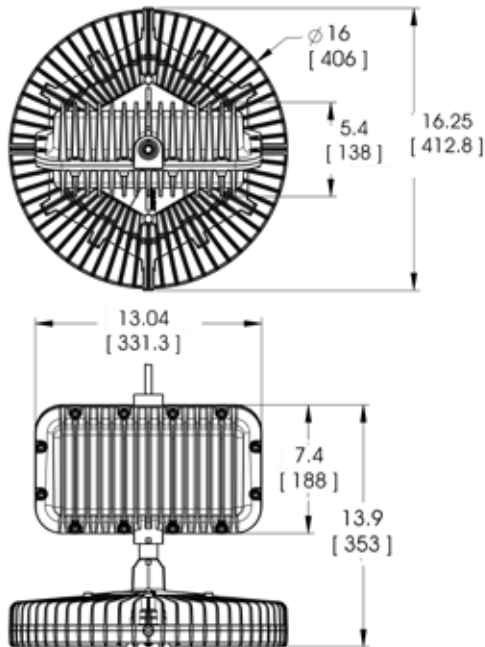

Dimensions in inches [mm]

Certifications & Ratings

- UL 1598/A
- CSA C22.2 #250
- IP66

Mechanical Information:

Fixture weight:	40 lbs (18 kg)
Shipping weight:	45 lbs (20 kg)
Mounting:	(1) 3/4" NPT - top (2) 5/16"-18 x .75" UNC - side
Entries:	10' (3.05m) STOOV Power Cord

Electrical Specifications:

Operating Voltage:	480V AC, 60Hz
Total system power consumption:	See table
Operating Temp:	-40°F to +149°F (-40°C to +65°C)
Harmonics:	IEC 61000-3-2
Noise requirement /EMC:	FCC Title 47, Subpart B, Section 15, class A device. RF Immunity; 10V/m, 80MHz-1GHz
Transient protection:	Protection devices capable of handling up to 6kV. Tested for 6kV/2 ohm combination wave, as per IEEE C62.41, line-line and line-ground
THD:	<20%
Power Factor:	> 0.9
Fusing:	Internal on black and red wire

Construction:

Housing:	Copper free aluminum
Finish:	Superior dual coat finish Sealed polyester topcoat Chemical-resistant epoxy prime
Lens¹:	Tempered glass

Photometric Information:

CRI:	75
CCT:	5000K (cool white)

All values typical unless otherwise stated (tolerance +/- 10%)

¹For information on chemical compatibility, please follow this link to reference Dialight's Chemical Compatibility Guide: www.dialight.com/pubs/MDTFCHEMRFLX001.PDF

Vigilant® LED High Bay 480V AC Passive Power Supply - UL / CSA

Ordering Information

Part Number	Fixture Lumens	Watt	Lumens Per Watt	CCT	Wet Locations	Voltage	Lens	Optical Pattern	
								Circular	Wide
Standard Models									
HEGMCPN-SNG	26,500	212	125	5000K (cool white)	IP66	480V AC	Tempered glass	•	
HEGMCPKN-SNG	18,000	144	125	5000K (cool white)	IP66	480V AC	Tempered glass	•	

All values typical unless otherwise stated, Lumen values are typical (tolerance +/- 10%).

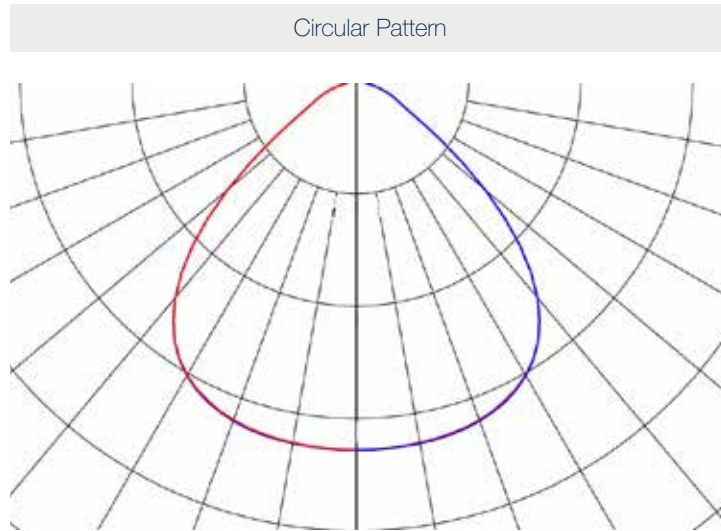

Vigilant® LED High Bay 480V AC Passive Power Supply - UL / CSA

Ordering Information and Mounting Accessories



HLXW2-SS

- 316 stainless steel swivel bracket and cable gland

HLXW3-SS

- 316 Stainless Steel swivel bracket



HBXL

- Loop



HBXH

- Hook



HLXW2

- Aluminum swivel bracket and cable gland

HLXW3

- Aluminum swivel bracket



HBXLENGC

- Clear tempered glass



HBXCG

- Cable gland



HBXCU

- Ceiling / wall mount

Vigilant® LED High Bay 480V AC Passive Power Supply - UL / CSA

Options and Accessories Drawings

HLXW3-SS - Swivel Bracket

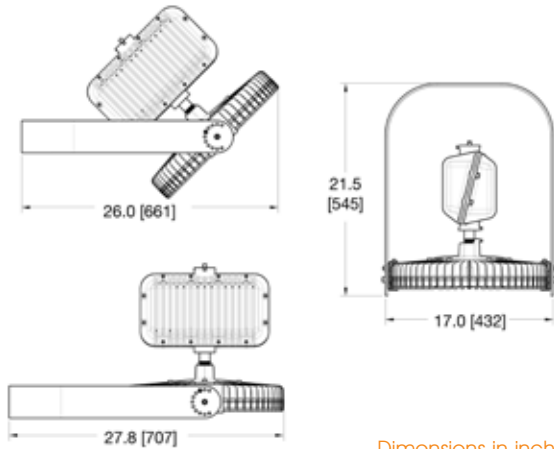

Dimensions in inches [mm]

HBXH - Hook

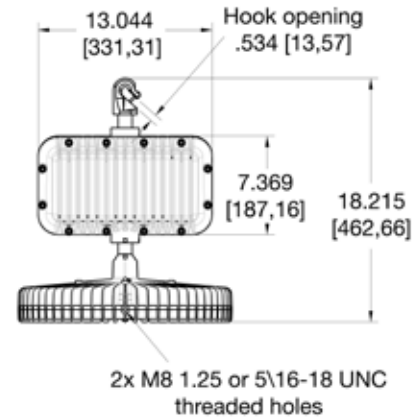

Dimensions in inches [mm]

HLXW3-SS - Swivel Bracket

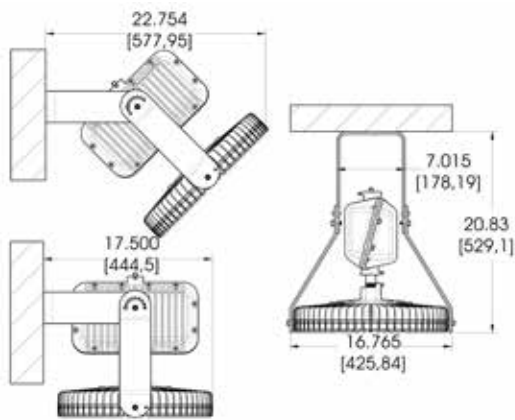

Dimensions in inches [mm]

