

---

INSTALLATION AND MAINTENANCE MANUAL  
FOR  
P/N: D564-XXX-001  
L864 RED MEDIUM INTENSITY BEACON

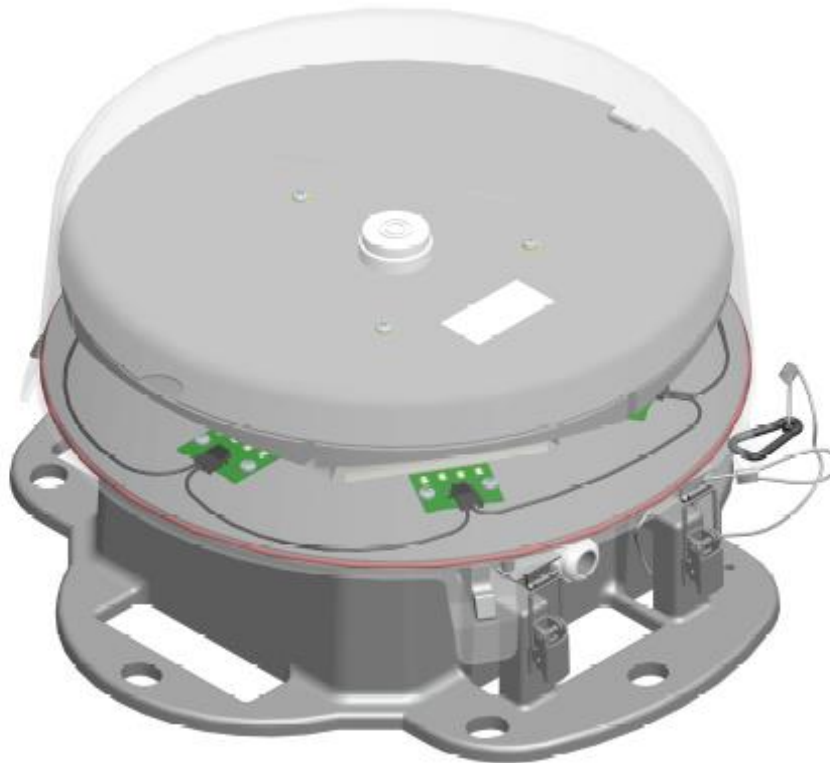

<b><u>Contents</u></b>	<b><u>Page</u></b>
<b>List of Figures and Tables .....</b>	<b>2</b>
<b>Reference Drawings .....</b>	<b>2</b>
<b>Section 1: Overview .....</b>	<b>3</b>
<b>Section 2: Wiring and Mounting .....</b>	<b>4</b>
<b>Section 3: Operation and Test .....</b>	<b>5</b>
<b>Section 4: Beacon Theory of Operation.....</b>	<b>5</b>
<b>Section 5: Maintenance and Troubleshooting.....</b>	<b>6</b>
<b>Section 6: Specifications .....</b>	<b>Error! Bookmark not defined.</b>
<b>Section 7: Regulatory Compliance and Certifications.....</b>	<b>8</b>
<b>Section 8: How to Obtain Warranty Service .....</b>	<b>8</b>
<b>Beacon Wiring Diagram .....</b>	<b>Error! Bookmark not defined.</b>

**List of Figures and Tables**

- Figure 1: L-864 Flashing Red Beacon Assembly
- Figure 2: Base - Bottom view
- Figure 3: System Block Diagram
- Figure 4: Beacon – External View
- Figure 5: Beacon in Open Position
- Figure 6: Light Engine Install/Removal
- Table 1: Troubleshooting

**Reference Drawings**

- Beacon Wiring Diagram

## **Section 1: Overview**

The Dialight Flashing Red Beacon is designed for the lighting of radio towers, wind generators and other obstructions to aerial navigation, as specified by the FAA, FCC, ICAO and Transport Canada. D564R models incorporate both Red and IR LEDs in a single unit to ensure visibility around military bases, airfield perimeters, buildings, towers and other obstructions for aircraft pilots, both during normal flight or when aided by night vision systems. Night Vision Goggles (NVGs) and Aviator's Night Vision Imaging System (ANVIS) often employ Class A, B, and C filters. These filters can reduce LED sources that emit light in the visible spectrum. The Vigilant L-864 D564 Series overcomes this obstacle by combining visible red LEDs and IR LEDs in a single unit.

The L-864 Flashing Red Beacon as shown in Figure 1, (hereafter referred to as the Beacon) operates from 120 / 240VAC 50/60 Hz or 24-48Vdc depending on the model number. The beacon consists of High Performance LED's that provide the light output equivalent to an incandescent fixture while consuming a fraction of the electrical power.

This manual provides guidance and recommendations for the installation and testing of the beacon assembly. Please read this document in its entirety before installing the Beacon.

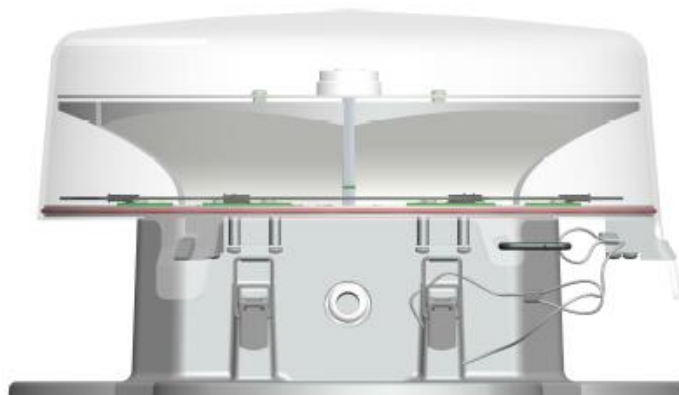

**Figure 1**  
**L-864 Flashing Red Beacon Assembly**

## Section 2: Wiring and Mounting

### Warning:

Remove power from all wiring and circuitry before installing or working on the Beacon.

### **Wiring the Beacon**

The Beacon only requires a connection to 120 / 240 VAC, 50/60 Hz or 24-48Vdc power depending on the model. The ground wire must be connected for proper operation and protection of the Beacon.

**NOTE:** If there is a possibility of water or moisture entering through the external power cable then the installer must install a wire loop or adequate protection to ensure the IP rating of the fixture is maintained in the installed environment.

### **Mounting the Beacon**

Dialight recommends the installation of one or more lightning rods near the installed Beacon. The lightning rods should extend a minimum of three feet above the height of the Beacon.

The Beacon is mounted to the tower pedestal utilizing customer supplied 1/2" hardware. Six mounting holes are provided on the Beacon base (Figure 2). These mounting holes will align with most tower pedestals. The Beacon must be installed level according to the bulls-eye level inside the light engine to maintain light output in accordance with FAA requirements.

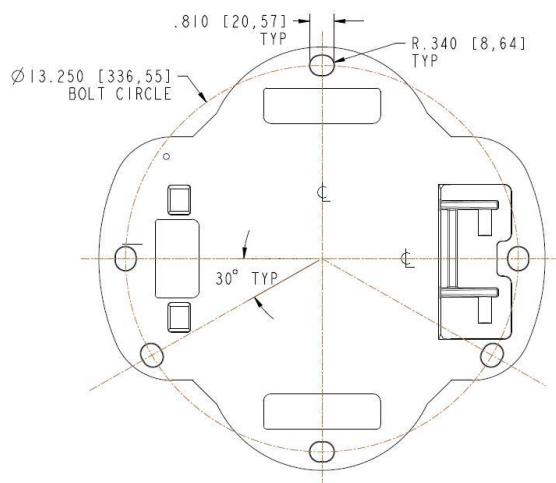

**Figure 2**  
**Base - Bottom View**

### **Section 3: Operation and Test**

Prior to installation, it is recommended that the unit be tested to ensure no damage was incurred during shipping. This is accomplished by applying power to the beacon. Visual verification of the functioning of the Beacon will indicate proper performance.

**WARNING:** Do not look directly into LED's. Adequate eye protection should always be used.

**NOTE:** Beacon is supplied as a steady burn unit and thus will not flash unless other modifications were requested and supplied with the unit.

Upon completion of this test, the installation may proceed.

### **Section 4: Beacon Theory of Operation**

#### **4.0 System Overview**

The block diagram in Figure 4 shows the major components of a typical Beacon installation. The parts of the system are the LED Beacon and Controller. The LED Beacon is made up of one LED module, which lights when current passes through it. The LED Beacon contains its own internal power supply. The Beacon is designed for use with an external controller. This external controller provides the properly timed flashing signal, fault monitoring and alarm interfaces.

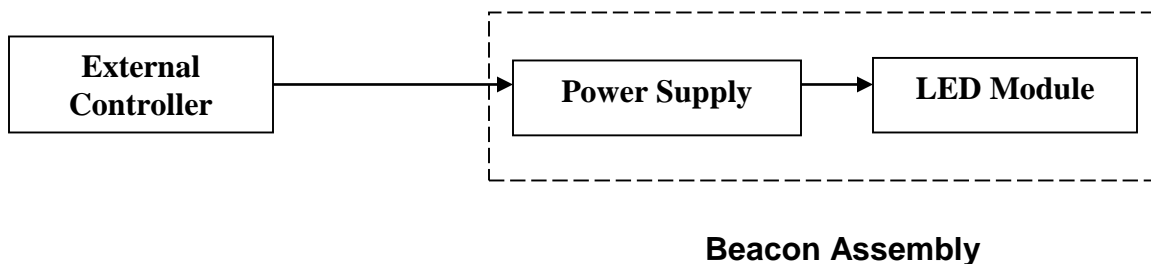

**Figure 3 - System Block Diagram**

#### 4.1 Lightning Protection

The Beacon incorporates protection against voltage surges (as induced by nearby lightning strikes for example) by means of a multi stage protection circuit utilizing the latest in arresting protective components.

#### **Section 5: Maintenance and Troubleshooting**

No regularly scheduled maintenance is required for the Beacon.

General cleaning of the Dome Assembly should be done using soapy water. No other cleaning solutions are recommended. Abrasive compounds will scratch the Dome Assembly.

Table 1 Lists possible faults and repair procedures for the L-864 Red Beacon

**Table 1 Troubleshooting**

<b>Symptom</b>	<b>Possible Cause</b>	<b>Corrective Action</b>
DC Beacon does not light	No external DC power  Red and black wires reversed  Broken connector	Verify proper DC levels from power source thru supply lines.
AC Beacon does not light	No AC power	Verify proper AC levels from power source thru supply lines.
Beacon does not flash	Refer to controller documentation supplied by the manufacturer.	

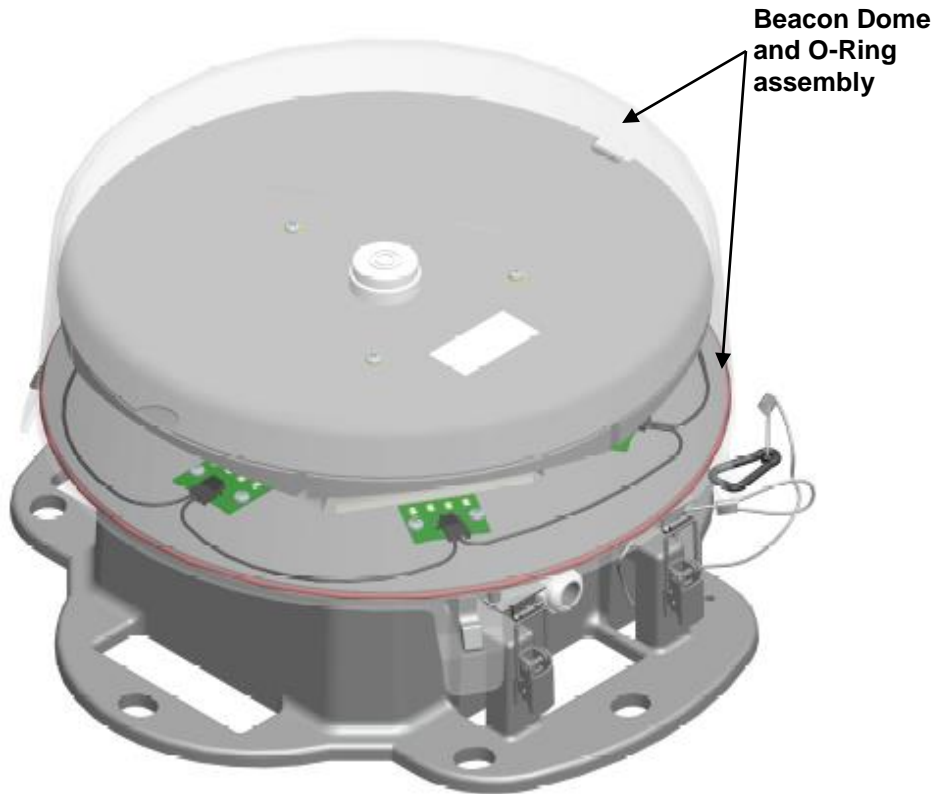

**Figure 4 Beacon – External View**

**Recommended spare parts, User replaceable parts**

<b>Description</b>	<b>Dialight Part Number</b>
Beacon Dome and O-ring	D464-2005

**Beacon Specifications**

Light Color	Red
Weight	22 Pounds
Height	8.4 Inches
Width	15.0 Inches
Bolt Hold down Pattern	Standard Pattern provided (See Fig. 2)

**Section 7: Regulatory Compliance and Certifications**

7.1 ETL Certified to: Federal Aviation Administration (FAA): AC No. (150/5345-43). Refer to website for latest certifications.

**Section 8: How to Obtain Warranty Service**

Refer to [www.dialight.com](http://www.dialight.com)

<b>REVISION HISTORY</b>
-------------------------

<u>REV</u>	<u>ECO No.</u>	<u>DRN</u>	<u>CKD</u>	<u>APP</u>	<u>QA</u>	<u>CM</u>	<u>DATE</u>
A	41496	BAM	SA	CAG	YS	JN	1/23/17