



**On when
it counts.**



TMT Australia Keeps Remotely Operated Vehicles (ROVs) Duty-Ready with Long-Life Dialight LED Fixtures

Maintenance-Free Hazardous Area Certified Lighting Eliminates Downtime for Lamp Changes in Offshore Drilling Environments, Saving Millions of Dollars in Lost Business



SafeSite® Bulkhead at Total Marine Technology

State-of-the-Art ROV Construction

Based in Bibra Lake, Western Australia, Total Marine Technology builds state-of-the-art Work Class Remotely Operated Vehicles (ROVs) and intervention tooling for offshore drilling and production applications. Over the last 14 years, TMT has built a reputation for design and build quality and reliable performance, winning a Western Australian Industry & Export Award for its world class excellence in engineering and technology, and a special commendation for manufacturing in the export award category.

Zero Availability for Downtime

When gearing up for a brand new installation on the ENSCO 5006 semi-submersible rig for drilling operations in Australia, TMT was looking for a more reliable solution than the conventional fluorescent and HID lighting it had been using on its ROVs.

Because of the critical nature of ROVs aboard the rig, the aim is to have them constantly available. ROV downtime for something as simple as changing lamps has the potential to be very expensive for operators or cause significant delays in production. Under the harsh vibration and seawater spray conditions, conventional lighting requires frequent maintenance, further complicated by the fact that many of the fixtures are mounted in areas where access is difficult. Because licensed electricians are not always available to

make the repairs, production could be delayed even longer until service personnel can be brought in. And, because the lights are in a hazardous area, a “hot work permit” would be required each time a fixture housing must be opened, rendering the ROV unavailable for duty.

“Due to the job intensity and requirement that the ROV be ready to deploy 24/7, we cannot afford to have any downtime,” said Slobodan Stankovic, electrical engineer with TMT. “Our customers depend on the availability of our ROVs, and we needed a better lighting solution in terms of both cost and quality that would allow the ROV crew to work around the clock to keep the unit operational and ready to go, instead of changing lamps.”

Dialight's Cutting-Edge LED Lighting Promises Maximum Efficiency, Performance

After evaluating several options TMT ultimately chose Dialight's SafeSite® Bulkhead and Area Light LED fixtures to outfit its new ROV for the ENSCO 5006. Citing the documented reliability, 5-year full-performance warranty and availability of the products required—IECEX certified fixtures for Zone 1 IIC with T5 temperature rating—TMT was confident the Dialight SafeSite Bulkhead and Area Light would meet or exceed its high standards for quality and performance. TMT's electrical team installed the fixtures, and on February 3, 2015 the ENSCO 5006 commenced drilling in the Brewster reservoir, more than 4,000m beneath the seabed.

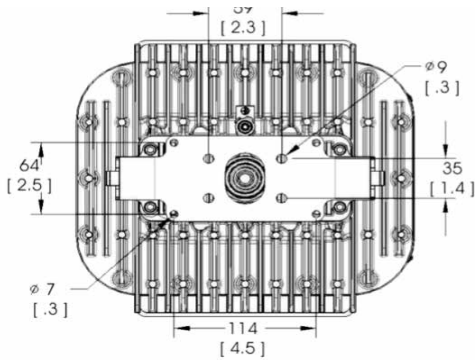

SafeSite® Area Light product diagram

Dialight Delivers Minimal Maintenance Maximum Benefit

Slobodan says the Dialight SafeSite Bulkhead and Area Light LED fixtures have performed “better than expected,” providing high visibility and excellent visual clarity by way of the crisp, clean white light, compared to the conventional fluorescent and HID lighting. With the longest-life performance guarantee in the industry, the Dialight fixtures mean crews will not have to worry about lighting maintenance for many years to come.

That's welcome relief to maintenance crews, as “some of the lights are fairly inaccessible and maintenance would not be a cheerful task,” Slobodan said. “Our crew is satisfied with the quality of the Dialight equipment and looking forward to not having to perform lighting maintenance for probably the next 10-15 years.”



For more information on Dialight's high-performance, long-life SafeSite hazloc certified LED lighting solutions for the petrochemical industry, visit www.dialight.com.

For more information about Dialight's high-performance, zero-maintenance LED lighting for industrial applications, visit www.dialight.com.