

Installation / Operating Instructions

These instructions contain safety information, read and follow them carefully.

Dialight will not accept any responsibility for injury, damage or loss which may occur due to incorrect installation, operation or maintenance.

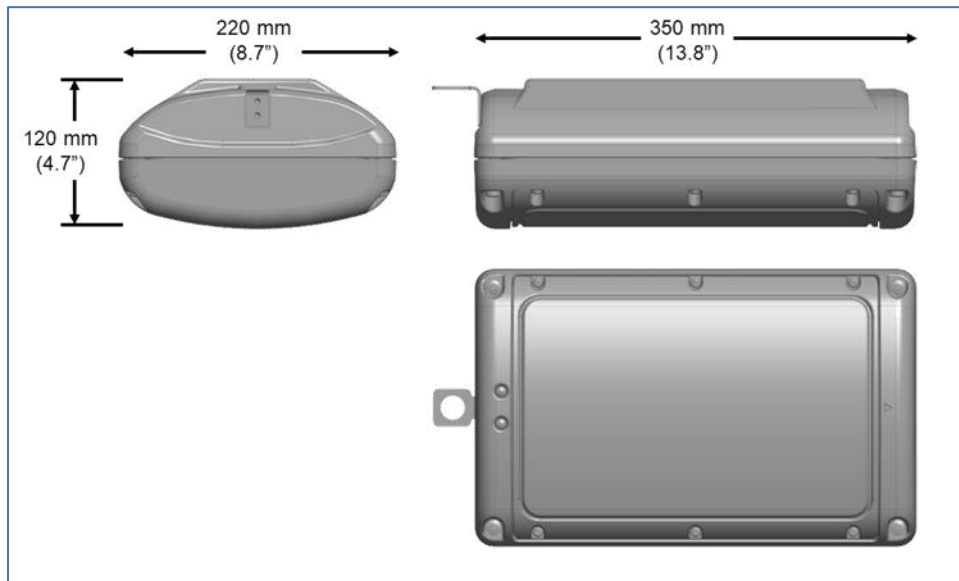

Note: Save these instructions for future use



WARNING: INSTALLATION & SECONDARY RETENTION. The use of this product without proper installation and inspections, including secondary safety retention/securing/netting, could cause severe injury or death. Dialight recommends that all installations should use secondary retention and/or safety netting (appropriate to the installation environment) where applicable. It is the exclusive responsibility of the contractor, installer and/or end customer to: (a) determine the suitability of the product for its intended application; and, (b) ensure that the product is installed safely (with secondary retention and/or safety netting where appropriate) and in compliance with all applicable laws and regulations. To the extent permissible under the relevant law, Dialight disclaims all responsibility for personal injury and/or other damage resulting from any dislodgement or other dislocation of this product.

ADVERTENCIA: INSTALACIÓN Y SISTEMA SECUNDARIO DE SUJECIÓN. Usar este producto sin haberlo instalado e inspeccionado correctamente, lo que incluye usar sistemas secundarios de retención/sujeción/redes, podría ocasionar lesiones graves o la muerte. Dialight recomienda que en todas las instalaciones se utilice un sistema secundario de retención o una red de seguridad (apropiados para el lugar de la instalación), según corresponda. Será responsabilidad exclusiva del contratista, el instalador o el cliente final encargarse de lo siguiente: a) determinar si el producto es apto para el uso previsto; y b) asegurarse de que el producto se instale de manera segura (usando un sistema secundario de retención o una red de seguridad, si corresponde) y de conformidad con todas las leyes y disposiciones aplicables. En la máxima medida autorizada por la legislación pertinente, Dialight no será responsable por ninguna lesión personal u otros daños que se produzcan a raíz de cualquier caída o desplazamiento de este producto.

AVISO: INSTALAÇÃO E RETENÇÃO SECUNDÁRIA. O uso deste produto sem a instalação e inspeções adequadas, incluindo retenção/fixação secundárias e/ou redes de segurança, pode provocar ferimentos sérios ou morte. A Dialight recomenda que todas as instalações utilizem retenção secundária e/ou redes de segurança (apropriadas ao ambiente da instalação) sempre que aplicável. É responsabilidade exclusiva da empreiteira, instaladora e/ou do cliente final: (a) determinar a adequabilidade deste produto para a aplicação pretendida; e, (b) assegurar que o produto seja instalado de maneira segura (com retenção secundária e/ou rede de segurança sempre que apropriado) e em conformidade com todas as leis e regulamentações aplicáveis. Dentro dos limites permitidos pela legislação pertinente, a Dialight se exime de toda responsabilidade por ferimentos pessoais e/ou outros danos resultantes do desalojamento ou de outro deslocamento deste produto.

AVERTISSEMENT : INSTALLATION ET FIXATION SECONDAIRE. L'utilisation de ce produit sans une installation et des inspections en bonne et due forme, notamment la sécurisation/ la fixation de sécurité secondaires/ l'installation d'une grille en acier tissée de sécurité, peut entraîner des blessures graves voire la mort. Dialight recommande que toutes les installations soient pourvues d'une fixation secondaire ou d'une grille en acier tissée de sécurité (adaptées à l'environnement de l'installation) dans la mesure du possible. Il va de la responsabilité exclusive de l'entrepreneur, de l'installateur ou du client final de : (a) déterminer si le produit est adapté à son usage prévu et (b) assurer que le produit est installé de manière sûre (avec une fixation secondaire et/ou une grille en acier tissée de sécurité le cas échéant) et en conformité avec la loi et les normes en vigueur. Dans la mesure permise par la loi en vigueur, Dialight n'assumera aucune responsabilité en cas de blessure sur la personne ou autre dommage résultant du déboîtement ou de toute autre dislocation de ce produit.

WARNING: INSTALLATION UND ZWEITE ABHÄNGUNG. Die Verwendung dieses Produkts ohne ordnungsgemäße Installation und Inspektionen, einschließlich einer zweiten Abhängung/eines Sicherheitsnetzes, könnte zu schweren Verletzungen oder Tod führen. Dialight empfiehlt bei allen Installationen die Verwendung einer zweiten Abhängung und/oder eines Sicherheitsnetzes (entsprechend der Installationsumgebung). Es ist die ausschließliche Verantwortlichkeit des Vertragsnehmers, Monteurs und/oder Endkunden: (a) die Eignung des Produkts für seinen vorgesehenen Nutzungszweck zu bestimmen und (b) sicherzustellen, dass das Produkt sicher (mit ggf. zweiter Abhängung und/oder einem Sicherheitsnetz) und gemäß allen geltenden Gesetzen und Vorschriften montiert wird. Soweit gemäß dem geltenden Gesetz erlaubt, schließt Dialight jegliche Haftung für Körperverletzung und/oder andere Schäden aufgrund einer Entfernung oder anderen Positionsänderung dieses Produkts aus.

WARNING:

To avoid the risk of fire, explosion, or electric shock, this product should be installed, inspected, and maintained by a qualified electrician in accordance with all applicable electrical rules and regulation.

Safety Instruction:

To avoid electric shock:

- Be certain electrical power is OFF before and during installation and maintenance.
- Luminaire must be connected to a wiring system with an equipment-grounding conductor.
- Make sure the supply voltage is the same as the rated luminaire voltage.
- The technical data indicated on the LED luminaires are to be observed.
- Changes of the design and modifications to the LED luminaire are not permitted.
- Observe the national/regional electrical safety rules and regulations during installation.

Technical Data:

Ratings and Certifications:

- CE / RCM
- IK 10 (polycarbonate)
- IP 66 / 67

Operating Temperature Range:

-40°C to +65°C (-40°F to +149°F)	Standard Design
-20°C to +55°C (-4°F to +131°F)	Battery Backup

Operating Voltage:

100–277 VAC 50/60Hz / 120–250 VDC	BH****2*****N
230/240 VAC	BH****G*****E/F/G
110/120 VAC	BH****1*****E/F/G

Power: See chart below

Housing Material:

Copper-free Cast Aluminum

Weight:

6.8kg (15lb)	Standard Design
7.7kg (17lb)	Battery Backup

POWER CHART:

All figures are **MAXIMUMS**

		Standard Design			Battery Backup		
		100Vac	230Vac	277Vac	100Vac	230Vac	277Vac
3klm WHITE	Wattage	22W	22W	22W	25W	25W	25W
	Input Current	0.22A	0.10A	0.08A	0.25A	0.10A	0.09A
6klm WHITE	Wattage	45W	45W	45W	48W	48W	48W
	Input Current	0.45A	0.20A	0.17A	0.48A	0.20A	0.17A
3klm AMBER	Wattage	24W	24W	24W	27W	27W	27W
	Input Current	0.24A	0.10A	0.08A	0.26A	0.11A	0.09A
5klm AMBER	Wattage	46W	46W	46W	49W	49W	49W
	Input Current	0.46A	0.20A	0.16A	0.49A	0.20A	0.17A
3klm GREEN	Wattage	27W	27W	27W	33W	33W	33W
	Input Current	0.27A	0.12A	0.10A	0.33A	0.14A	0.12A

Luminaire Application:

The luminaire can be used inside or outside to illuminate general areas.

Always transport and store the luminaire in its original packaging and keep in a dry location.

When unpacking, check for any cracks or damage to the castings and lens. If in doubt, do not install.

CAUTION: It is important to ensure that the application structure can support the weight of the luminaire.

Dialight is not responsible for damage to application structure or to luminaire, if mounted improperly.

Inspect the luminaire prior to installation for any physical defects.

If any physical defects are noticed, **DO NOT** install luminaire and contact a Dialight representative.



Mounting of Luminaire

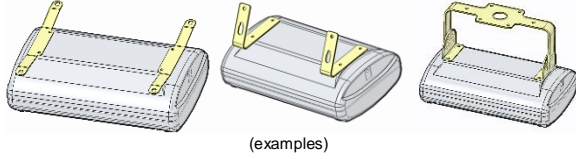

Secure mounting bracket to luminaire
(refer to separate manual for mounting options)

Electrical Connections

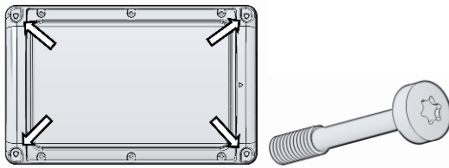

Unthread corner captive screws
CAUTION: DO NOT REMOVE HARDWARE

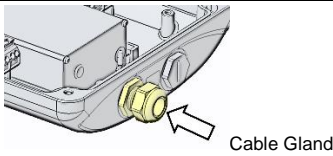

Feed source cable through cord grip

Terminal Block Connection



For push down style: 12-20 AWG (4.0-0.5 mm²) 10-11 mm (0.39"- 0.43")
For cage clamp style: 10-20 AWG (6.0-0.5 mm²) 11-13 mm (0.43"- 0.51")

Strip source cable conductor jacket

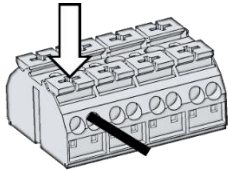

Push down, insert source conductor and release.
Slight tug on source conductor to check engagement
WARNING: Only single cable for each terminal entry point.



NON-BATTERY DESIGN

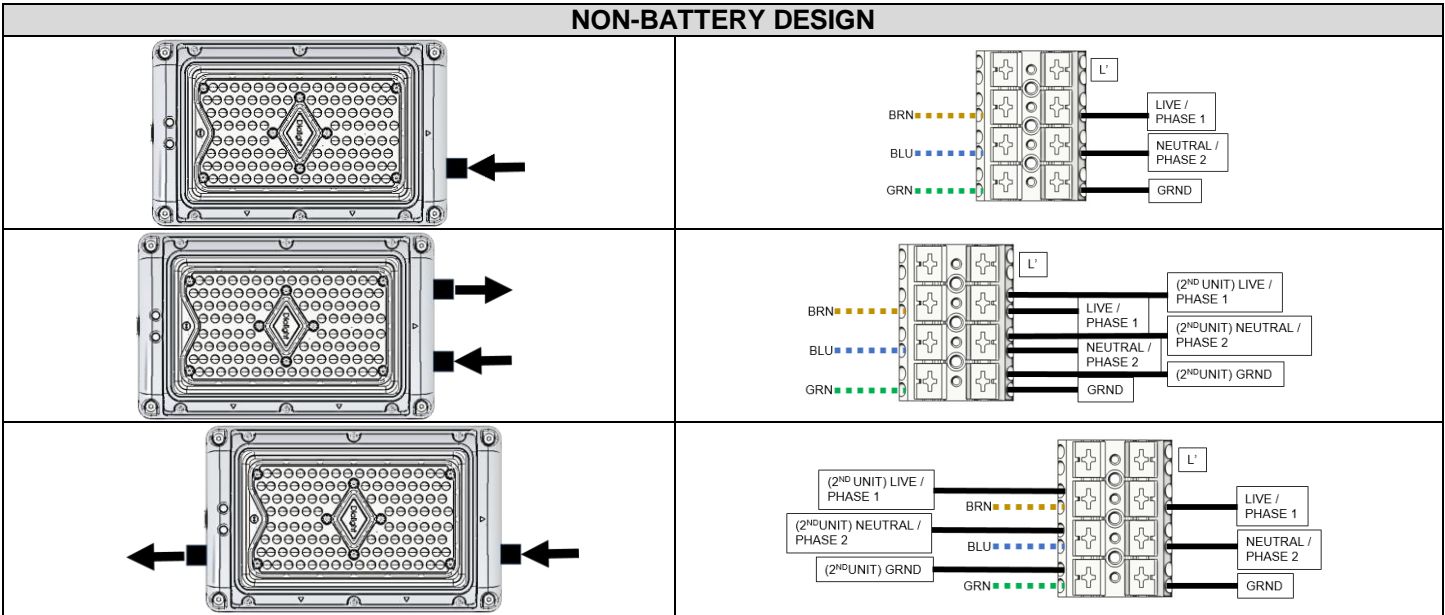

Electrical Connections (DALI or Dimming Compatible)

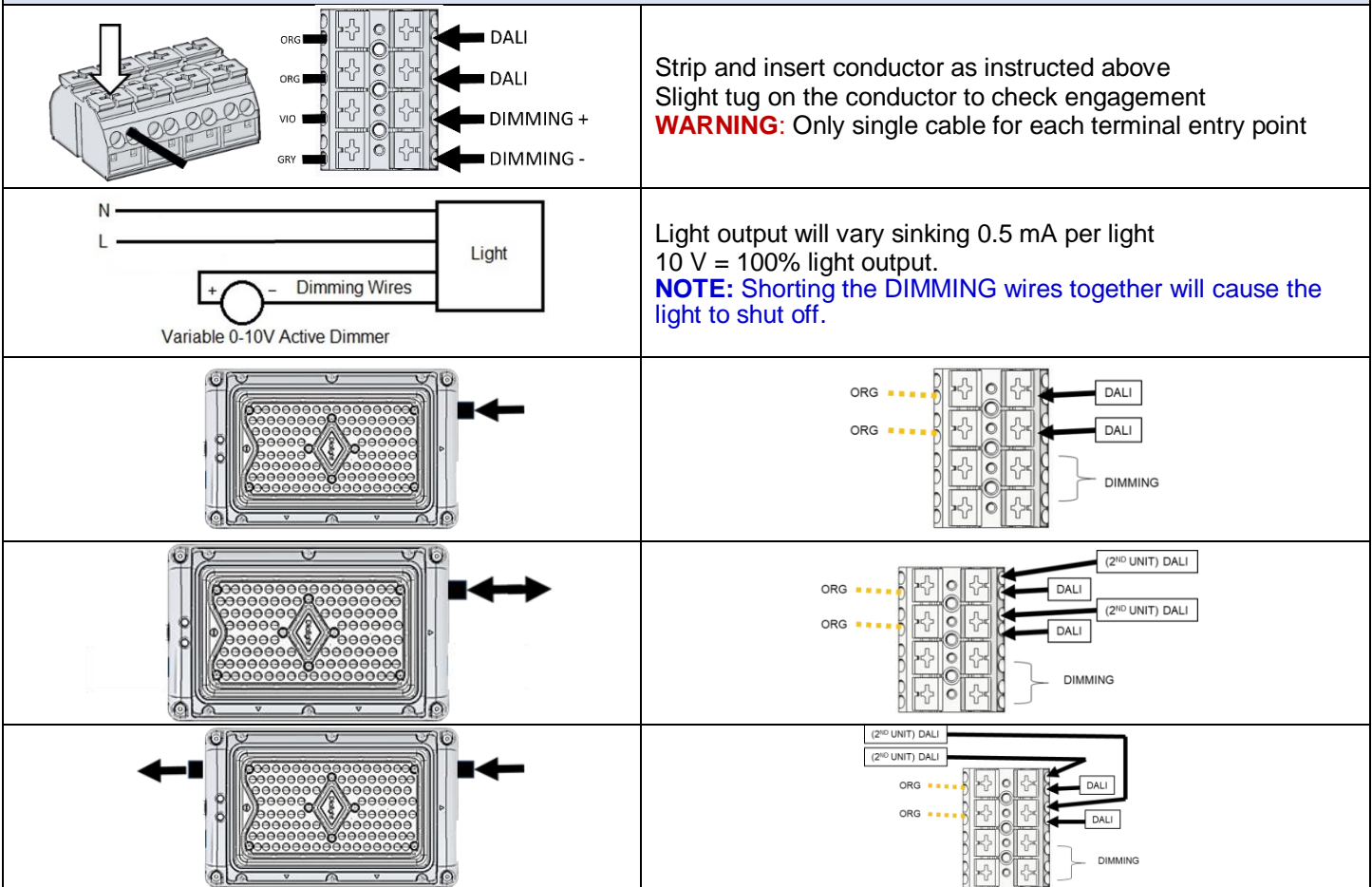

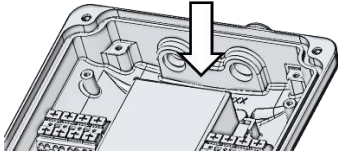
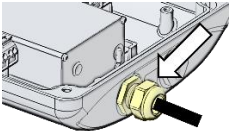
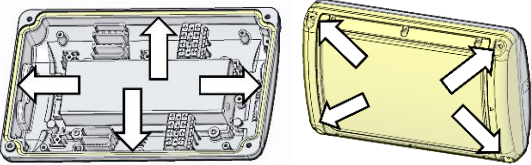
Closing Luminaire	
	<p>After illumination confirmation, tuck excess cable into luminaire</p>
 <p>M20 Torque: 2.3-2.7 N-m (20-24 in-lb)</p> <p>3/4 NPT Torque: 4.7-5.2 N-m (42-46 in-lb)</p>	<p>Tighten cord grip to secure cable</p>
 <p>Torque: 1st = 1 N-m (8.8 in-lb) FINAL = 5 N-m (44.2 in-lb)</p>	<p>Ensure O-ring is in place and not damaged <i>CAUTION: Ensure cables will not be pinched</i> Tighten corner captive screws (opposite corner sequence)</p>



Battery Backup Connection

Battery Pack is **only** charged during AC operation
 Once AC power is lost, **BATTERY MODE** is enabled and will stay on based on the configuration jumper position (**Fig.A**) below.

BATTERY LIFE: The battery pack should be replaced every **3 years**
ATTENTION: Luminaire requires a minimum of **24 continuous hours** of normal operation before the batteries are fully charged. If AC power is interrupted, then the 24 hour clock restarts.

SELF-TESTING: The Luminaire performs 3 tests automatically and at random times:

Install Duration Test	runs a duration test after 24 continuous hours of normal operation, the light will go into BATTERY MODE based on the configuration jumper
Function Test	will be performed monthly, light will remain in normal operation during test
Annual Duration Test	runs a duration test after 1 year of normal operation, the light will go into BATTERY MODE based on the configuration jumper

GREEN LIGHT = Indicates **NORMAL** status **RED LIGHT** = Indicates **SYSTEM FAULT** status
 Refer to table to identify meaning of flashing lights. Mark battery with date of install.

Battery Indicator Signals		Slow Flash = 0.5 Hz	Fast Flash = 2.5 Hz	
Mode	Indicator LED	System Status	Battery LAMP	Stand-alone / DALI
Battery Standby	Green ON Pulse Every 10s	Normal	Off	Both
Battery Charging in Progress	Green ON Pulse Every 10s	Normal	Off	Both
Function Test in Progress	Green Fast Flash	Self Testing	On	Both
Duration Test in Progress	Green Slow Flash	Self Testing	On	Both
Battery Operation	All Off	Emergency	On	Both
Lamp Fault	Red Fast Flash	Fault	Off	Both
Battery Charging Fault	Red Slow Flash	Fault	Off	Both
Battery Duration Fault	Red Slow Flash	Fault	Off	Both
Identification	All Fast Flash	Normal	Off	DALI Mode Only
Rest	All Off	Emergency	Off	DALI Mode Only
Prolong	All Off	Emergency	On	DALI Mode Only

Battery configuration jumper positions



Electrical Connections (Battery Backup)

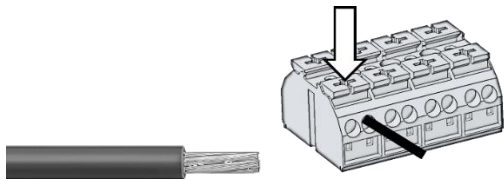

(for all connections)
Strip and insert source conductor as instructed above
Slight tug on the conductor to check engagement
WARNING: Only single cable for each terminal entry point

PERMANENT MAINTAINED CONNECTIONS

Light is always on, maintains charging, battery mode enabled with loss of AC power

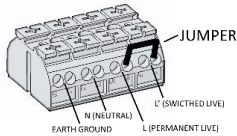

Jumper in place (from factory)

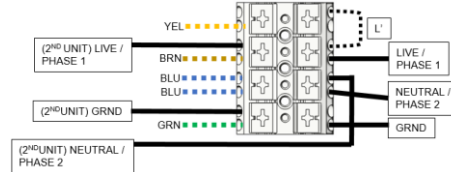
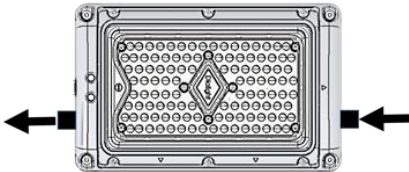
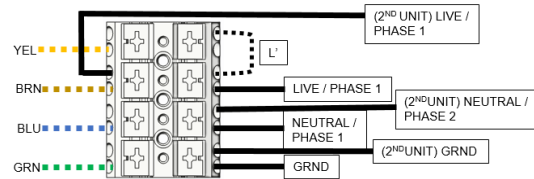
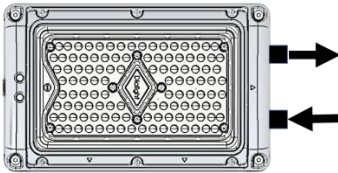
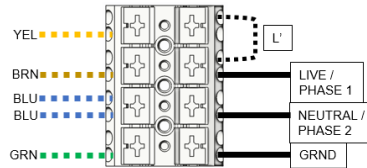
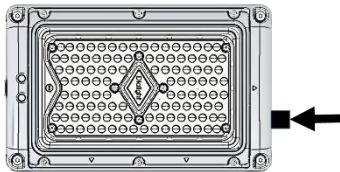

SWITCHED MAINTAINED CONNECTIONS

Switch is added to L` to switch the light on/off, maintains charging, battery mode enabled with loss of AC

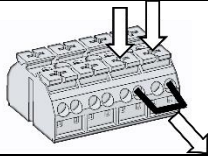

Push down, **remove** jumper and release

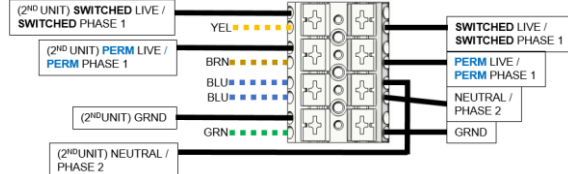
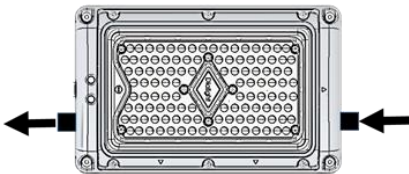
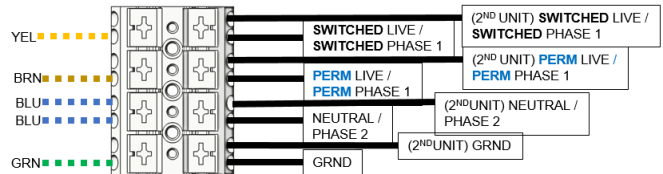
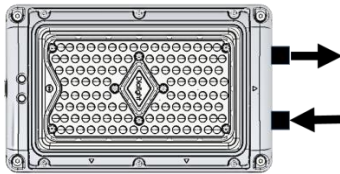
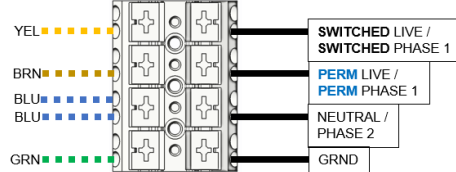
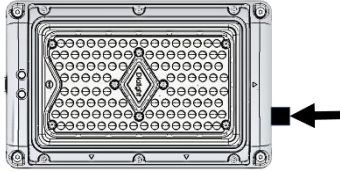

NON-MAINTAINED CONNECTIONS

Light is off normally, maintains charging, battery mode enabled with loss of AC

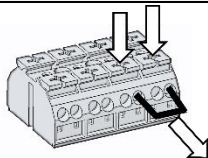

Push down, **remove** jumper and release

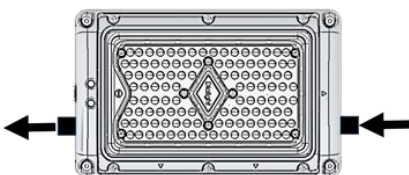
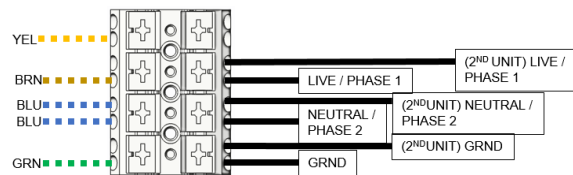
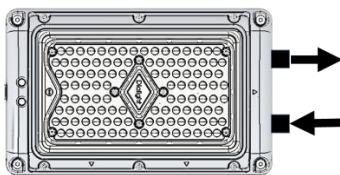
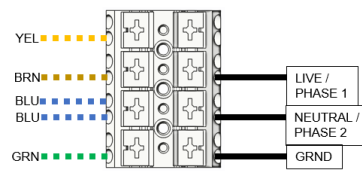
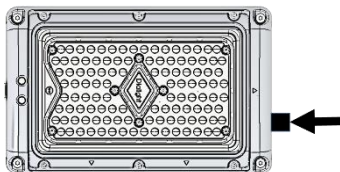

Power and Illumination Check	
	<p>Restore power to check for illumination CAUTION: Do not look directly into luminaire without protective shaded eyewear</p>
Final Orientation of Luminaire (Adjustable Bracket Only)	
<p style="text-align: center;">Pivot bolt Locking bolt</p>	<p>Loosen pivot bolt WARNING: DO NOT REMOVE Remove locking bolt WARNING: DO NOT DISCARD</p>
	<p>Tilt to proper angle (15° increments)</p>
<p style="text-align: center;">Torque = 7 N-m (5 ft-lb) Torque = 34 N-m (25 ft-lb)</p>	<p>Reinstall angle locking bolt and tighten Tighten pivoting bolt</p>
Secondary Safety Retention (optional)	
<p style="text-align: center;">Hole = Ø 19mm (.75")</p>	<p>Feed cable/chain/etc through bracket Some slack after installation is suggested</p>



Conditions and Use in Normal Operations:

Prior to regular operation, check the luminaire for its correct installation and compliance with these instructions and other applicable regulations.

WARNING: Dialight is not responsible for improper installation or improper use that does not conform to application regulations.

Disposal Recycling:

When the luminaire is disposed of, the respective national/regional regulations on waste disposal should be observed.



Maintenance and Inspection:

The luminaire requires a minimum amount of maintenance but if any unforeseen repairs are required, please contact Dialight or an authorized representative.

- It is suggested the lens window and any exterior surfaces to be cleaned periodically using a damp, non-abrasive, lint free cloth.
- It is suggested that routine inspections are conducted. Frequency of use and environment should determine this.

Chemical Compatibility Guide:

Chemical compatibility is highly dependent on concentration, temperature, humidity, and other environmental conditions and therefore the customer assumes responsibility for evaluation of gaseous or direct contact chemical compatibility at their site prior to product installation.

Contact your local Dialight representative for more information.

Repairs / Overhaul / Modification:

The operation of the luminaire must be in accordance to the intended purpose and undamaged condition. Changes and modifications are not permitted to the luminaire.

NOTE: Should the luminaire enclosure be damaged, only a full luminaire replacement will be permitted. In case of doubt, the luminaire should be returned to Dialight for inspection/repair.

Official Statement

All statements, technical information, and recommendations contained herein are based on information and tests that Dialight believes to be reliable. The accuracy or completeness thereof is not guaranteed. In accordance with Dialight Terms and Conditions of Sale and since conditions of use are outside our control, the purchaser should determine the suitability of the product for his or her intended use and assumes all risk and liability whatsoever in connection therewith.

