

VIGILANT® SERIES
Dual Red/White (L-864/865)
White Lighting System (L-865)

DHZCPSD4C8 – C1D2 Power Supply

with

DHZBFHD4C – C1D2 Flashhead

&

DHZCCTD8C80x0 – C1D2 Controller

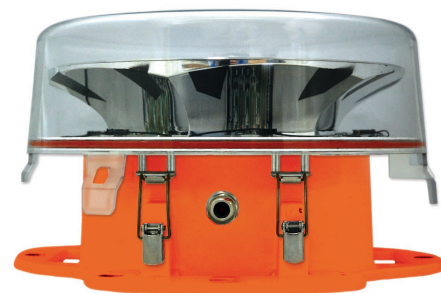

**READ AND FOLLOW ALL SAFETY INSTRUCTIONS**

- **DO NOT let any supply cords touch hot surfaces higher than cord ratings.**
- **DO NOT mount near gas or electric heaters**
- **Equipment should be mounted in locations and at heights where it will not be subjected to tampering by unauthorized personnel.**
- **The use of accessory equipment not recommended by the manufacturer may cause unsafe conditions.**
- **DO NOT use this equipment for other than intended use.**
- **DO take pictures: Installation Photos Required for Warranty Coverage. (All electrical connections, bonding, system support and grounding)**
- **Refer to Quick Manual for list of required pictures and commissioning checklist**
- **The cable information provided are for cable lengths less than 680 feet.**
- **The operation and maintenance must be carried out by authorized personnel.**
- **Repairs and Installation must only be carried out by a qualified electrician.**

SAVE THESE INSTRUCTIONS!!

- **Only genuine Dialight replacement parts must be used when unforeseen repairs are required.**
- **Observe the national safety rules and regulations during installation!**
- **Earth Grounding is required throughout the install process. Failure to do so could void all warranties!**
- **No alterations should be done without agreement from Dialight Corp. Alterations other than written in this manual will void all warranties.**
- **The light source contained in this luminaire shall only be replaced by the manufacturer or his service agent or a similar qualified person.**
- **Explosion Hazard – Do not disconnect equipment unless power has been switched off or area is known to be non-hazardous.**
- **Explosion Hazard - Do not remove or replace any components while circuit is live unless area is known to be free of ignitable concentrations.**
- **Explosion Hazard – Substitution of any components may impair suitability of Class I Division 2 Rating and void warranty.**

SAVE THESE INSTRUCTIONS!!

Table of Contents:

INTRODUCTION:.....	4
WARRANTY:	4
SYSTEM DESCRIPTIONS:.....	5
TYPICAL SYSTEM OVERVIEW:.....	5
NOTICE AND WARNINGS:	6
DIMENSIONS FOR MOUNTING THE ENCLOSURE:.....	7
DIMENSIONS FOR MOUNTING THE DHZB L864/865 FLASHHEADS:.....	8
ELECTRICAL SPECIFICATIONS:.....	10
ENVIRONMENTAL SPECIFICATIONS:.....	10
INSTALLATION TIPS AND REQUIREMENTS:	10
SYSTEM CABLE SPECIFICATIONS:	11
POWER SUPPLY COMPONENT LAYOUT:	12
CONNECTION OF INPUT POWER:	13
CONNECTION OF THE RS485 CABLE:	14
TRANSLATOR BOARD SETTINGS:.....	15
FLASHHEAD CABLE PREPARATION:.....	16
FLASHHEAD/POWER SUPPLY CABLE CONNECTIONS:	17
SPARE PARTS - POWER SUPPLY:.....	19
COMMISSIONING PHOTOGRAPHS:	20
TECHNICAL SUPPORT:	20
SERIAL NUMBER CODING:	20
REVISION HISTORY:	20



Introduction:

This manual is for installing the FAA Type E (L-864/865, Dual Red/White), FAA Type D (L-865, White only) and FAA Type A (L-864, red Only) lighting systems within a Hazardous Location area.

Covered in this manual is the following information.

- Warranty Policy
- System Descriptions & System Overview
- Notice and Warnings
- Dimensions of DHZCPSx4C8 Power Supply Enclosure
- Dimensions of DHZBFHx4C Flashhead
- Electrical & Environmental Specifications
- Installation Tips and Requirements
- System Cable Specifications
- RS485 Communication Connections for multiple systems
- Power Supply Component Layout
- AC Power, RS485 & Flashhead Connections
- Spare Parts for Power Supply
- Commissioning Photographs
- Technical Support
- Serial Number Coding

Not included in this manual:

Refer to the DZHC Controller Manual for the below information

- Controller Status LED's
- Dry contact connections
- Navigating the LCD Display in Main Controller
- Display Events and Alarm Descriptions
- Alarm list and possible causes

Warranty:

Please visit www.dialight.com/resources/warranties for the latest warranty policy.

System Descriptions:

The below devices are covered in this manual. The listed power supplies will require a controller (DHZCCTD8C80x0) with photocell (DHZB6000PEC) for proper operation. See manual 9100127202299 for additional information on Controller, Sidelights, and Photocell.

DHZCPSx4C8	Gen6 Dual Red/White C1D2 Power Supply 120/277AC 50/60Hz Input Voltage L-864/865 or L-865 flash head, 4 conductor cable required
DHZBFHD4C	Gen6 Dual Red/White w/4 conductor C1D2 Flash Head - Configured in controller as Dual Red/White or White Only

System not listed, please contact Dialight technical support at 844-436-5422.

Typical System Overview:

The below diagram is a typical system layout that will utilize a central controller, four RTO style L-810 side markers, and four DHZB L-864/865 flashheads. One additional tier of RTO sidelights along with up to four additional power supplies can be connected to a central controller.

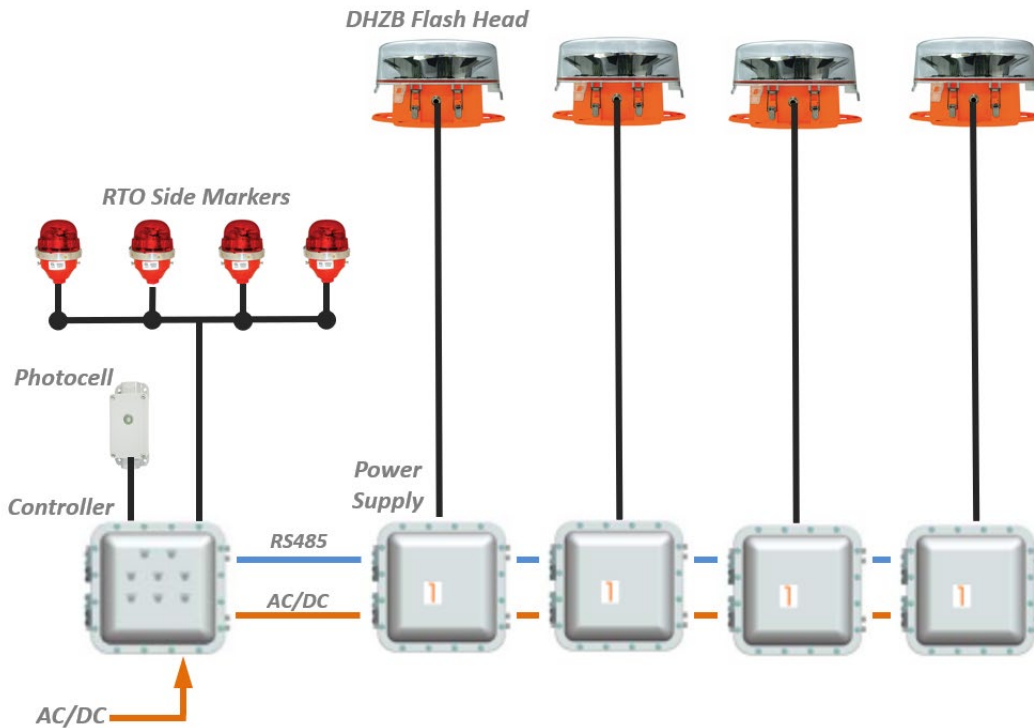

Notice and Warnings:

This manual contains important information regarding the proper installation, operation, and maintenance of this product. Before using the product, read and understand all instructions, cautions, notes and warnings, as well as all of the labels affixed to the product. Failure to do so could result in personal injury or damage to equipment and/or void the product warranty.



FAILURE TO LEAVE THE ENCLOSURES FREE FROM DEBRIS UPON COMPLETION OF INSTALLATION MAY CAUSE SHORT CIRCUITS

FAILURE TO TIGHTEN DOWN CLAMP WASHERS WILL MAKE INTERNAL COMPONENTS VULNERABLE TO SURGE OR LIGHTNING DAMAGE

FAILURE TO PROPERLY BOND THE EARTH GROUND WIRE TO THE JUNCTION BOX WILL RESULT IN EVENTUAL LIGHTNING DAMAGE OF THIS SYSTEM. TO AVOID WARRANTY NULLIFICATION, FOLLOW THE DIRECTIONS IN THEIR ENTIRETY.

CAUTION: ONLY APPROVED DIALIGHT PHOTOCELLS CAN BE USED WITH THIS SYSTEM

FAILURE TO PROPERLY BOND THE FLASHHEADS AND CONTROLLER ENCLOSURE TO THE TOWER STRUCTURE WILL RESULT IN EVENTUAL LIGHTNING DAMAGE OF THIS SYSTEM. THE SYSTEM'S WARRANTY SHALL BE VOID IF ALL FLASHHEADS AND CONTROLLER ENCLOSURE ARE NOT PROPERLY BONDED TO THE TOWER STRUCTURE. TO AVOID WARRANTY NULLIFICATION, FOLLOW THE DIRECTIONS IN THEIR ENTIRETY.

CAUTION: NEVER LOOK AT THE FLASH HEAD WHILE THE SYSTEM IS ENERGIZED. THE FLASH HEAD COULD START FLASHING CAUSING TEMPORARY BLINDNESS WHICH WOULD BE DANGEROUS AT HIGH ELEVATIONS.

FAILURE TO SET UP THE SYSTEM CORRECTLY DURING STARTUP MAY RESULT IN THE TOWER HAVING TO BE CLIMBED AGAIN TO PERFORM TROUBLESHOOTING.

USE PROPER METHODS OF LIFTING AND CARRYING TO PROTECT AGAINST INJURY. FOLLOW THE RECOMMENDATIONS BELOW TO ENSURE ENCLOSURES ARE HANDLED IN A SAFE MANNER:

- **BASED ON FACILITY SAFETY REQUIREMENTS DETERMINE IF THE ENCLOSURE REQUIRES TEAM LIFTING**
- **BEND AT THE KNEES AND MAKE SURE YOUR BACK IS STRAIGHT BEFORE LIFTING**
- **LIFT WITH YOUR LEGS AND NOT YOUR BACK**
- **KEEP THE ENCLOSURE CLOSE TO YOUR BODY WHILE CARRYING**
- **KEEP YOUR BACK STRAIGHT WHEN LOWERING**

Dimensions for Mounting the Enclosure:

- Recommended mounting hardware diameter is 5/8" (15.875mm)
- Weight of the complete enclosure is approximately 180 lb. (82 kg)
- Three (3) 3/4-inch NPT entrance holes provided on bottom side of enclosure.
- Three (3) 3/4-inch NPT entrance holes provided on right side of enclosure.

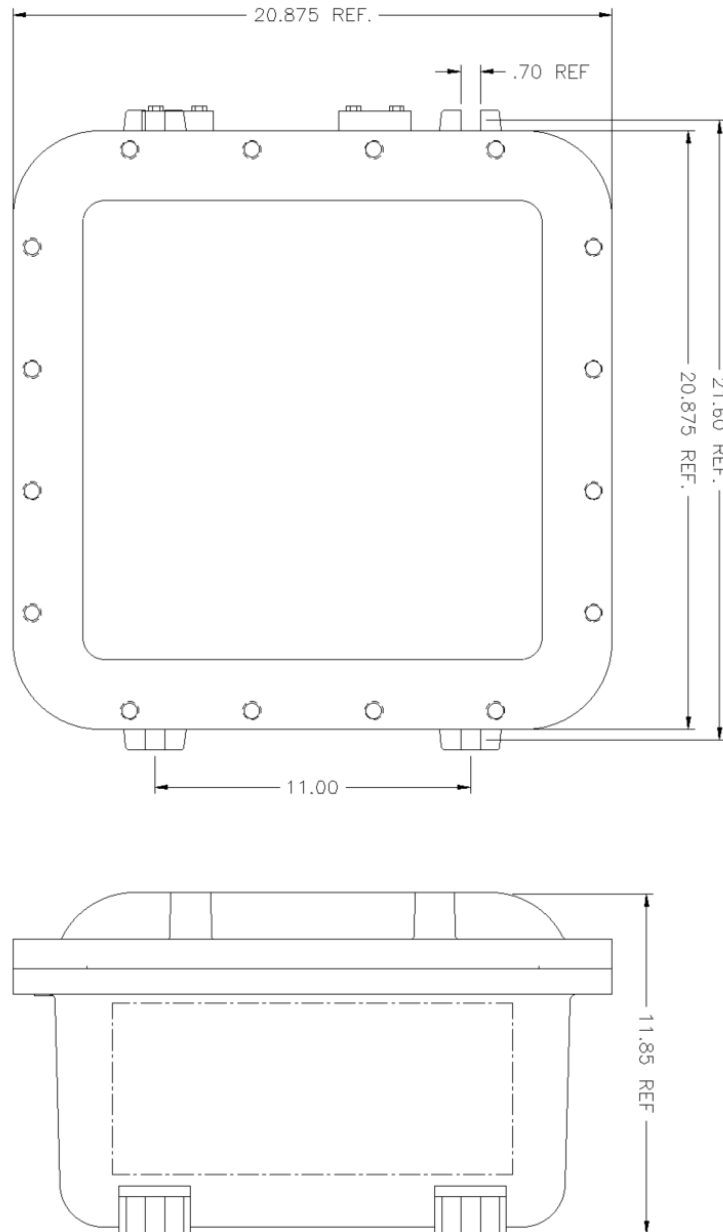

Dimensions for Mounting the DHZB L864/865 Flashheads:

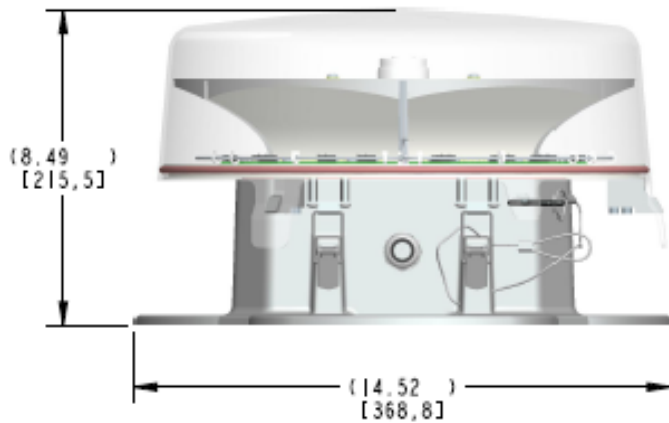
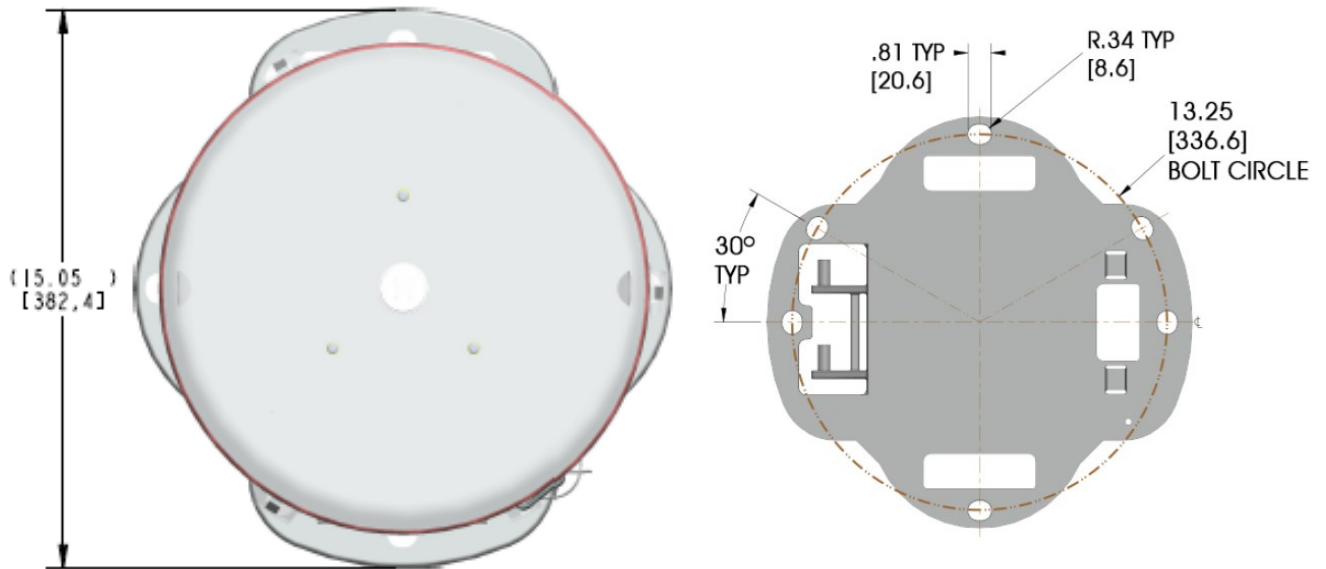

DHZBFH Flashhead
 Weight 21 lbs.(9.5kg)



Recommended Locations for Cable Entry:

The enclosures are supplied with six factory-drilled holes. All entrance holes must be properly sealed with Hazardous Location style fittings to ensure proper classification protection. Typical port entrances for cables/seal-tight are shown below.

NOTE: Dimensions are suited for $\frac{3}{4}$ -inch NPT fittings.

NOTE: Additional Grounding can be added at either the mounting feet or inserted to the ground terminal block (GL) located in the enclosure. Use supplied Grounding Kit supplied with enclosure. See instructions (9100127204799) for details.

Multiple grounding points are provided in the enclosure for protective and functional Earth/Ground connections.

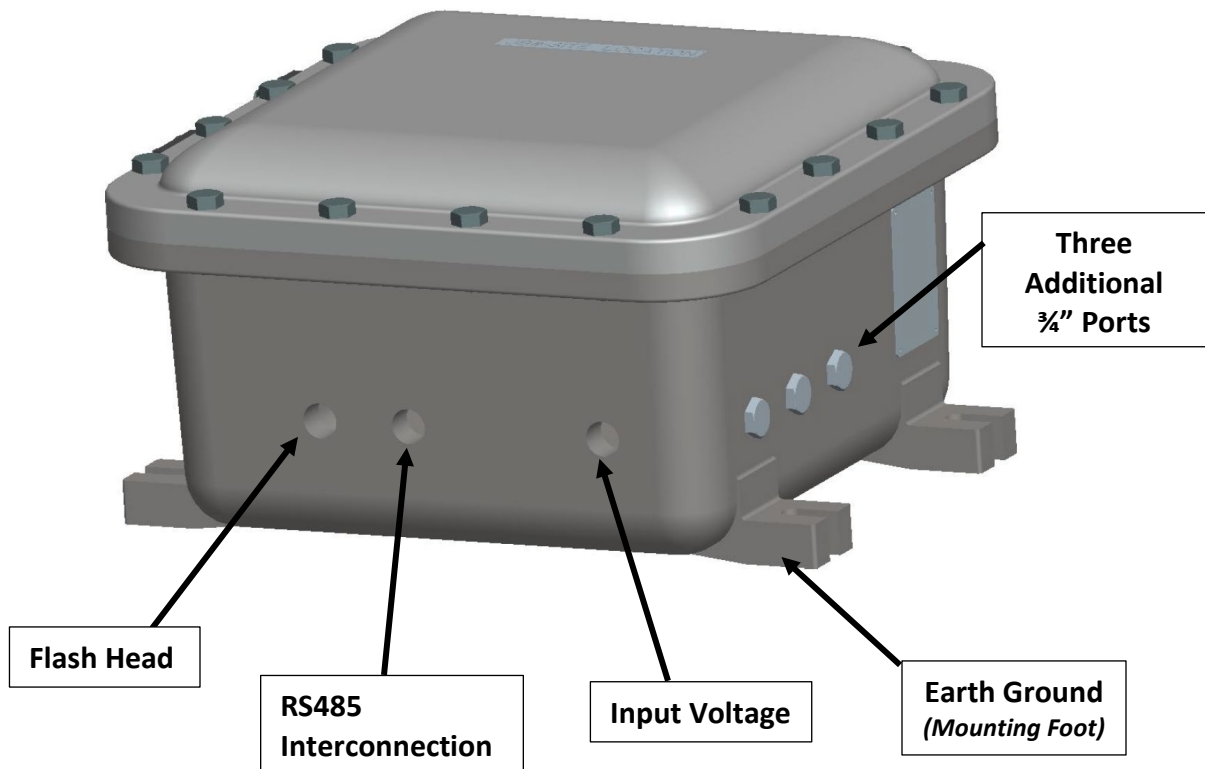

Electrical Specifications:

DHZCPSD4C8 Power Supply – 85 Watts max, 120-277 VAC 50/60Hz or 125VDC \pm 10%

Environmental Specifications:

Operating Temperature Range: -40°F to +130°F (-40°C to +55°C)

Humidity: 95% relative humidity

Wind: up to 150 mph (240kmph)

Protection: Class 1, Division 1 & 2, Groups B, C, D

Temperature Rating: See Enclosure Label

Equipment intended to be installed at an altitude of 2000m or less

Installation Tips and Requirements:

The DHZC Power Supply is housed in a NEMA7/9 rated outdoor enclosure and can be installed either outside or in a shelter. If installed outside, the installer must consider water ingress and proper earth grounding to reduce the risk of premature failures.

For AC or DC Input, it is recommended that the electrician or installer calculate the wire requirements based on the system being installed. It is recommended that installation does not utilize less than 14AWG 600V cable with at least a 90°C temperature rating. See electrical parameters for further information.

It is recommended that the lighting system be on its own breaker adequately rated for the system's power consumption. The breaker **MUST** be rated for at least 20% higher than the system's total current draw.

Proper grounding techniques must be utilized based on local, state and federal guidelines and customer specifications. The system has built in Lightning and RF immunity at each section, but for it to be effective proper ground connection techniques must be used.

System Cable Specifications:

NOTE: Cables for AC/DC Input and remote monitoring are not supplied.

Specification for Input cable:

Requires three conductors for AC or DC Input.

Typical 120-277VAC color code is Black, White, and Green.

Typical 125VDC color code is Red, Black, and Green.

Earth Ground is required in the controllers.

A minimum of 14AWG is to be used.

Bonding ground wire when required is to be 6AWG.

Individual wires can be used in lieu of a cable but must be routed through conduit or seal tight rated for Hazardous Locations.

Specification for RS485 Cable:

Requires three conductors of 18AWG, drain wire plus a braid for grounding.

Typical color code is Grey, Yellow, and Blue.

Specification for the Flashhead cable

The Vigilant® flashhead requires a 4-conductor cable with a minimum of 14 AWG with foil and braid shielding.

Typical colors are Red, Red with Black stripe, White and White with Black stripe.

Cable needs to be an un-cut (no splices) run from flashhead to power supply surge protection devices.

NOTE: Stripes are always for the negative connection on DC systems.

All cables or conduits must be properly secured to the structure to meet Hazardous Location requirements. Minimum #14-AWG cable length is 680 feet (207 meters). #12-4C should be used on taller structures.

Failure to meet any of the above cable requirements could void all factory warranties. If in doubt please contact your sales representative or Dialight.com.

Power Supply Component Layout:

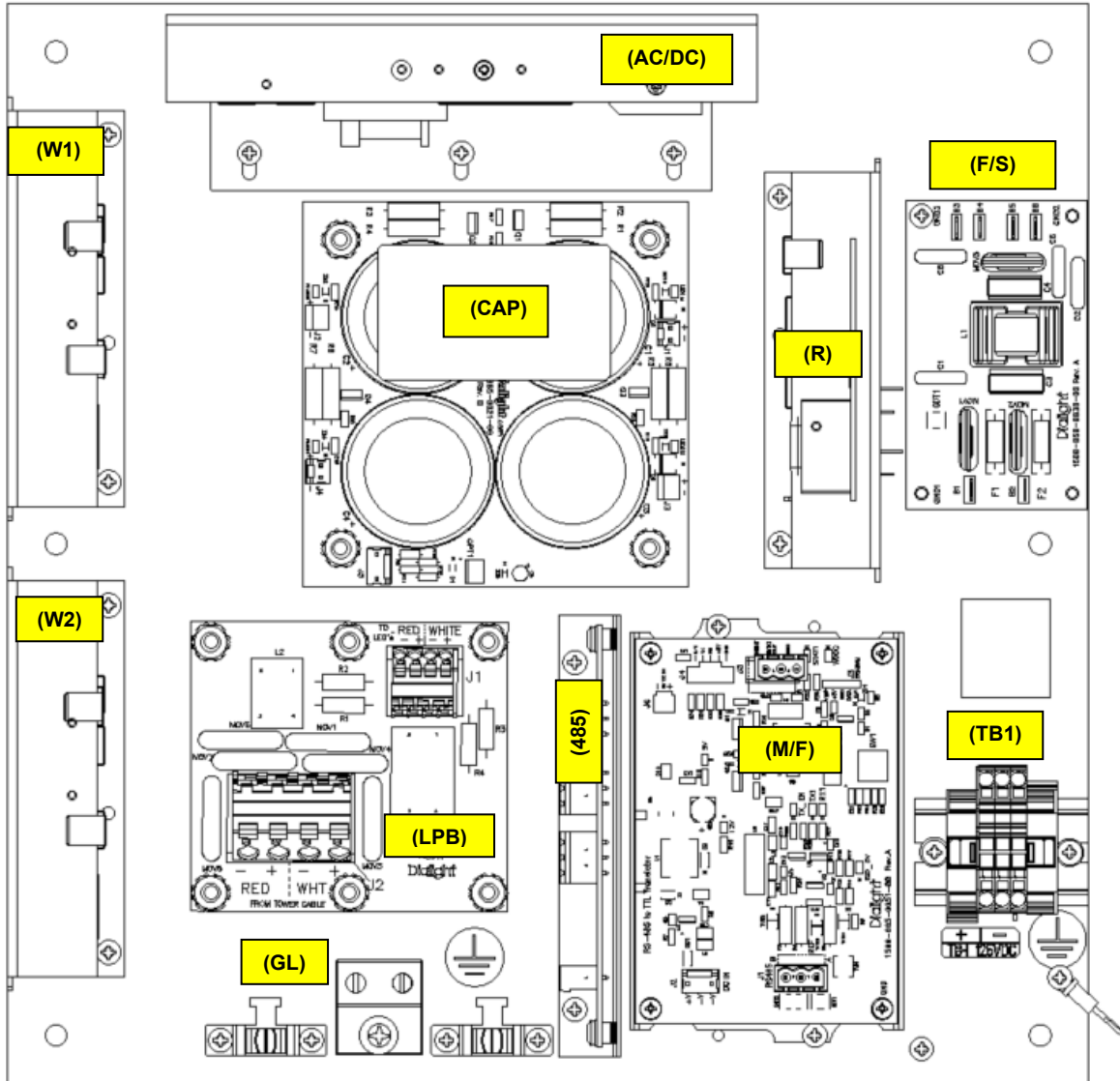

Item	Description	Item	Description
W1	WHITE LED DRIVER #1	AC/DC	POWER SUPPLY CONVERTER
W2	WHITE LED DRIVER # 2	M/F	MICRO/FILTER ASSY
GL	EARTH GROUND LUG	CAP	CAPACITOR BOARD
TB1	INPUT VOLTAGE (AC or DC)	LPB	LIGHTNING PROTECTION BOARD
F/S	FILTER/SURGE BOARD	R	RED LED DRIVER
485	RS485 CONNECTION POINT		



Connection of Input Power:

Input cable or wire is NOT supplied with the system. Input power connected at terminals labeled TB1 (see below).

- The AC connection requires three conductors. Live, Neutral and Earth Ground. Input Voltage is 120/277 VAC 50/60Hz (100-305 VAC max range).
- The DC connection requires three conductors. Positive, Negative and Ground. Input Voltage is 125VDC \pm 10% (112-138VDC max range).

Individual wires can be used but must be fed through hazardous approved seal tight or conduit. Earth ground connection is required to provide safety and proper operation of the system.

WARNING: Floating Neutrals are not permissible within the wiring of the system and the installer must verify the connections. This will “Void” all warranties and cause system failure during turn on.

WARNING: No more than 305VAC measured from Live to Earth Ground or Live to Neutral on TB1, or 137VDC from Positive to Negative or Positive to Ground. This must be measured before powering up the system.

NOTE: The load and voltage loss of the cable must be quantified before selecting the cable size requirements. See electrical specifications for details.

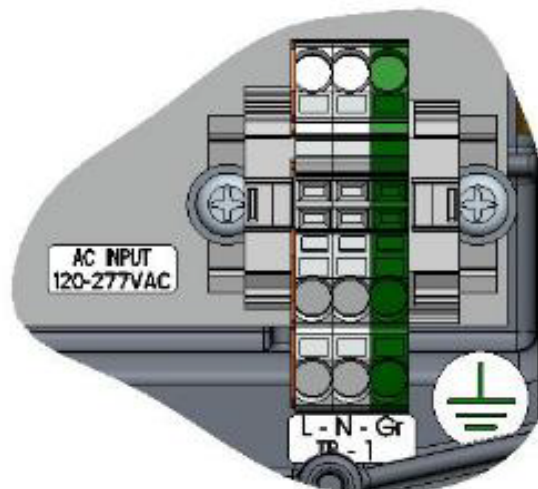

Connection of the RS485 Cable:

A 3-conductor cable with braid and foil is required for the interconnection of the RS485 between the main controller and power supplies at RS485 Connection Boards. The minimum size will be 18AWG.

The connection between the units is vitally important to the operation of the system. All communication of mode, sync, alarms, and events are transmitted on this connection between units back to the main controller.

The factory color code will be as follows on top of RS485 terminal block:

Terminal	Description	Color Code
Label "A"	Communications "A"	Gray
Common	Common for RS485	Yellow
Label "B"	Communications "B"	Blue

Braid/Foil should be properly stripped back away from the terminal block. The bare drain wire should be connected to the internal ground lug within the power supply.

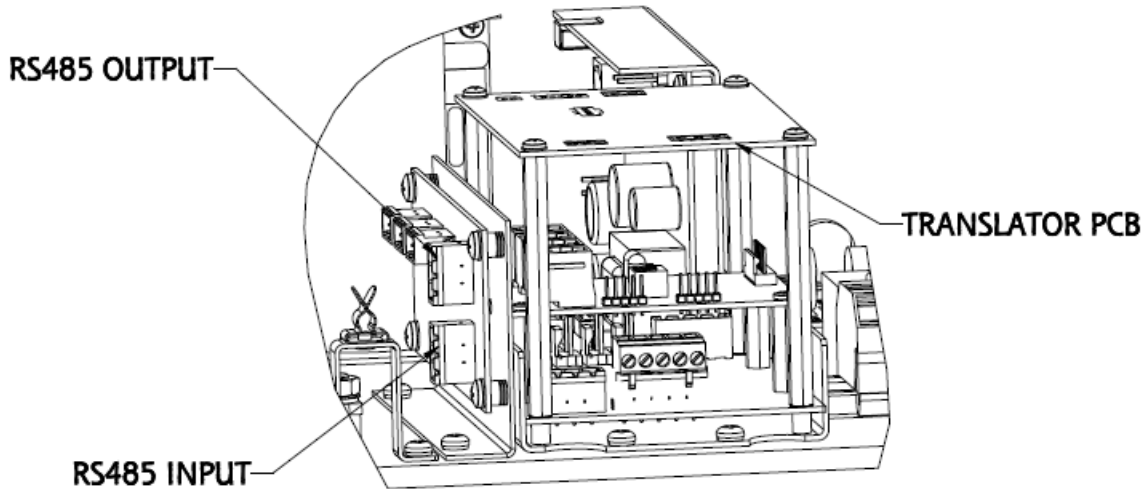

Interconnection between Main Controller and subsequent power supplies.

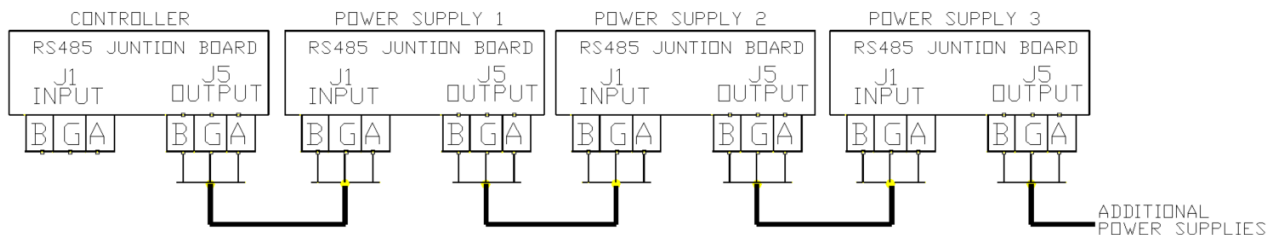

Translator Board Settings:

The translator boards (located in upper right corner of the power supply) needs to be individually assigned a number in order to communicate with the main controller and the rest of the system.

Factory setting is “0” zero.

Translator Board Rotary knob “SW1” settings, the use of a small flathead screwdriver is required. Failure to set the addresses will cause “config alarms” and “communications alarms”.

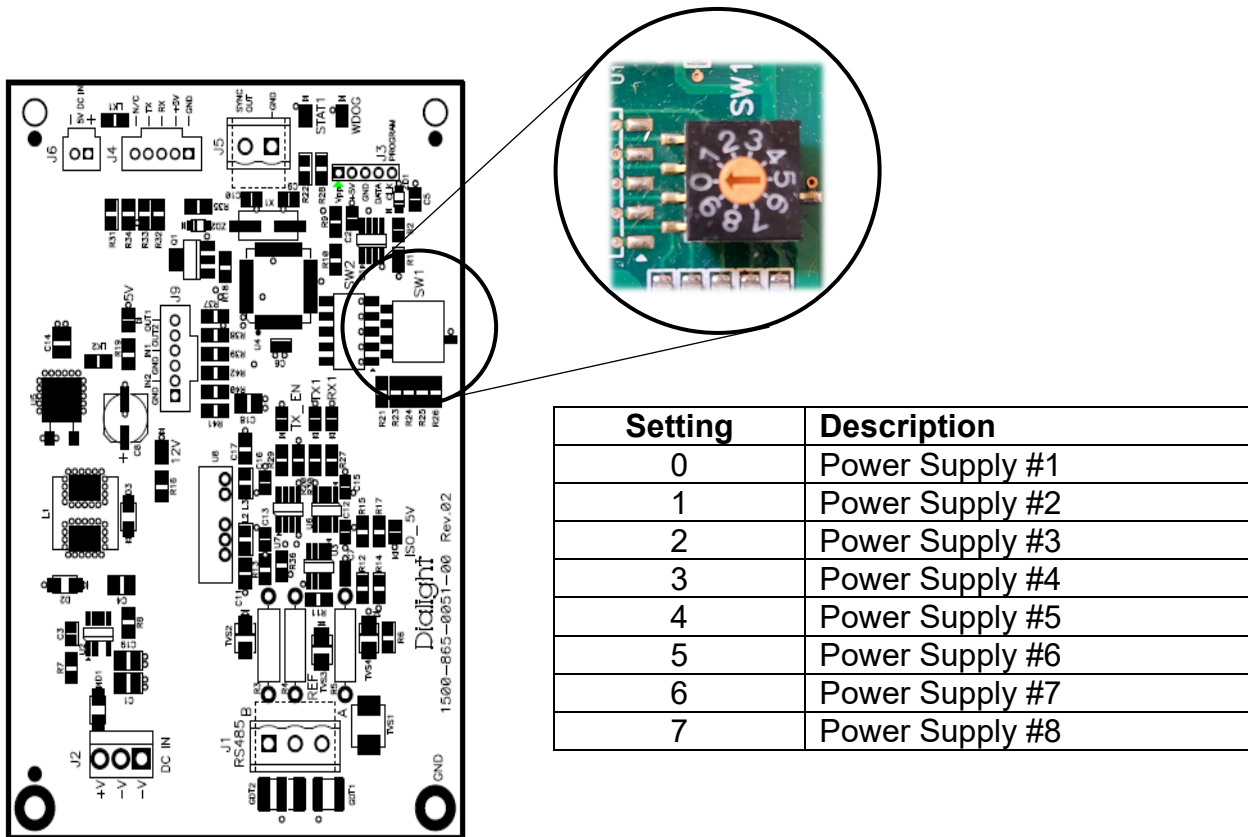

Setting	Description
0	Power Supply #1
1	Power Supply #2
2	Power Supply #3
3	Power Supply #4
4	Power Supply #5
5	Power Supply #6
6	Power Supply #7
7	Power Supply #8

NOTE: If the setting is changed when power is on, the system will need to be reset for the change to be recognized by the main controller.

Verification of operation can be confirmed by the illumination of the multiple LEDs located on the translator board.

5V	12V	ISO 5V	TX_EN	TX1	RX1	WDOG	STAT1
Green Solid	Green Solid	Green Solid	Amber x2 Flash	Amber x2 Flash	Amber x2 Flash	Green Fast Flashing	Green Slow Flash



Flashhead Cable Preparation:

1. Run the cable through the provided strain relief before stripping the outer jacket in order not to fray the braiding.
2. Remove 10" of the outer jacket. Careful not to damage internal braid. If cut, cable should be re-stripped to ensure proper bonding.
3. Wrap electrical tape 3-4" from end of outer jacket to prevent fraying.
4. Remove remaining braiding for the wires to be connected at flashhead terminal block (Red/Black, Red, White/Black, and White) back to electrical tape.
5. Strip conductors back 3/8" for termination into terminal block.
6. Connect the four conductors to terminal block and ground connection as detailed the next section.



Flashhead/Power Supply Cable Connections:

Flashheads and Power Supply have the same surge/terminal connections so the information below will be used for connecting inside the Flashhead. Use same installation method for the controller.

The flashhead cable must be an uncut run from the flashhead to the controller.

Mixing wires will result in severe damage to the controller and/or flashhead. This will VOID all warranties.

NOTE: This is the only connection in the flashhead pedestal that is required.

NOTE: If color code is different than shown, the installer must provide this information to the site manager upon completion for future reference when required.

Terminal block in Flashhead shown
 Using a small tipped Flat head screwdriver, insert and lift handle upwards to push the internal latch down to insert the wire.
 Do a pull test to ensure conductor is properly seated.

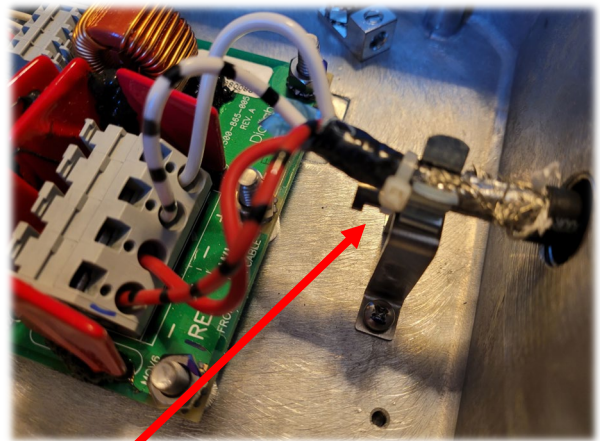

**Insert braiding in to the clip and use zip tie to secure to clip.
 See NOTICE on inside lid of flashhead for more details.**

J2 pin designators	Description
RED Connections (RED)	
- Pin 1 (Red/Black wire)	RED LED's negative (Cathode connection)
+ Pin 2 (Red wire)	RED LED's positive (Anode connection)
White Connections (WHT)	
- Pin 3 (White/Black wire)	WHITE LED's negative (Cathode connection)
+ Pin 4 (White wire)	WHITE LED's positive (Anode connection)



Terminal block in Power Supply shown
Using a small tipped Flat head screwdriver, insert and lift handle upwards to push the internal latch down to insert the wire.
Do a pull test to ensure conductor is properly seated.

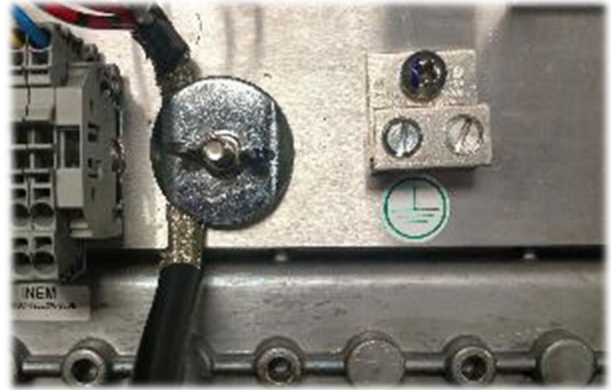

WARNING: It is vitally important that the braid and foil be properly connected under the clamping washers for lightning protection. Failure to do will result in premature failures during lightning strikes.

NOTE: For commissioning the system, pictures must be taken of all the clamping washers and the cables secured under them.



Spare Parts - Power Supply:

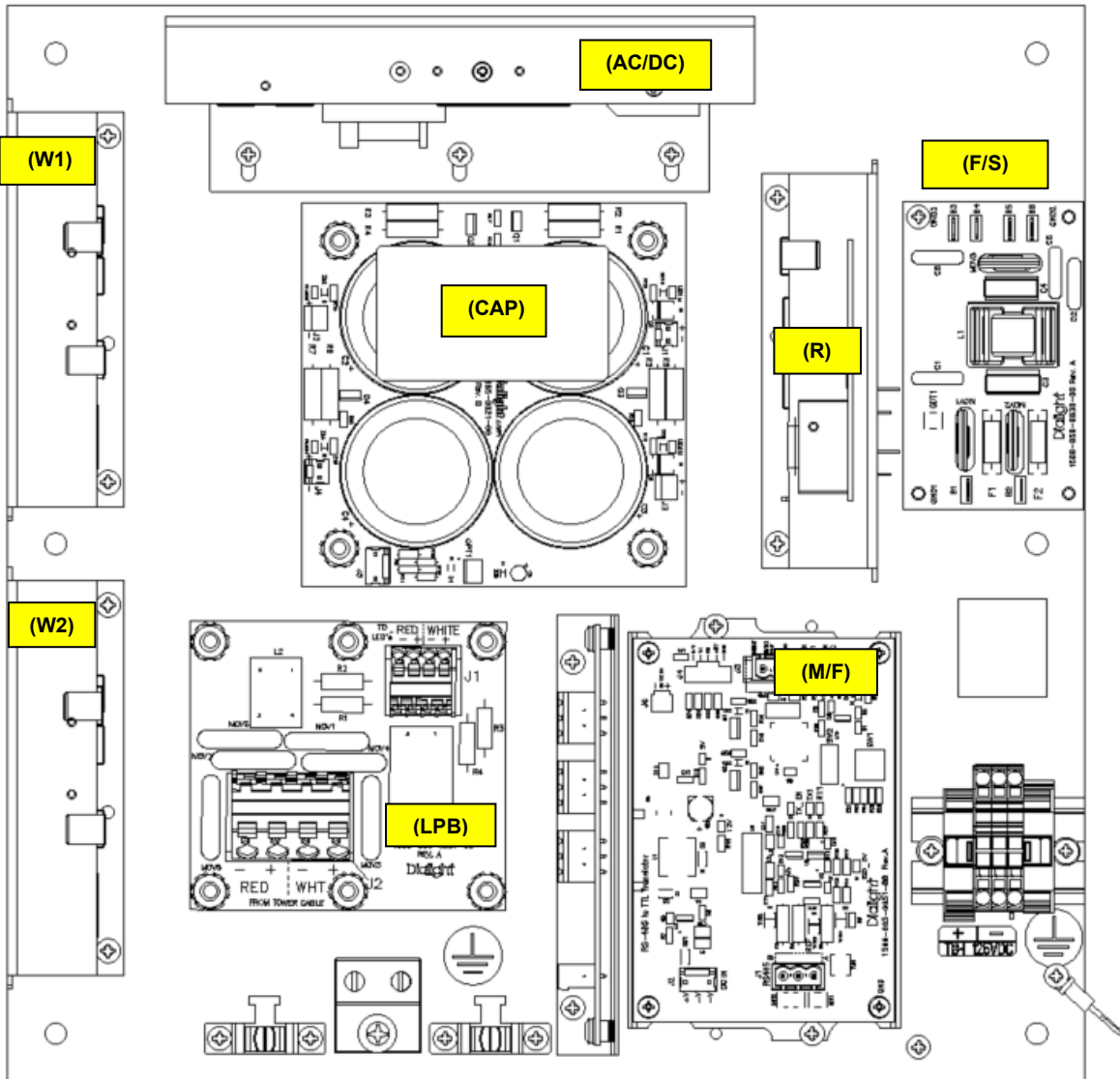

ID	Description	Part Number
W1 / W2	WHITE LED DRIVER BOARD	D1RW0084W
CAP	CAPACITOR BOARD	D1RW0084CP
LPB	LIGHTNING PROTECTION BOARD, Non-IR	D7203SUR
M/F	MICRO/FILTER ASSY	D7300ASY
R	RED LED DRIVER, Non-IR	D1RW0084R
AC/DC	POWER SUPPLY CONVERTER	D1RW9005RA
F/S	FILTER/SURGE BOARD	D7202SUR



Commissioning Photographs:

The following photographs should be taken and supplied to end-user (system owner).

1. Internal wiring of the Flashhead
2. Flashhead mounting to the structure (showing ground lug and service loop)
3. Additional Earth bonding the pedestal to the structure. (If applicable)
4. Any and all service loops for flashhead.
5. ESD brushed or lightning rods installed.
6. Labels on the flashhead and power supply.
7. All internal wiring in controller (AC Input, RS485, Flashhead).

Technical Support:

Engineering Technical Support Contact Phone Number

844-436-5422

Press 1 for Medium Intensity

Press 3 for Product Information

Serial Number Coding:

The serial numbers of the fixtures being installed are located on the Dialight label. Dialight refers to the serial numbers as **Date Codes**. The date code is used to determine warranty status of the unit. The Date Codes are set up as:

- The following YY, DDD, S/N.
- YY= the year it was produced
 - DDD= Julian day of the year
 - S/N= a number of either 3 or 4 digits.

Revision History:

REV	ECO No.	DRN	CKD	APP	QA	CM	DATE
A	14911	SA	DW	JLM	JP	JN	12/11/13
B	40142	CAG	BAM	SA	YS	JN	1/9/17
C	71912	CV	AV	DW			8/7/20
D	116539	JAJ	ER	JC	YS	SA	4/11/24

